



LISTING INFORMATION OF
Mitek Design No. MCI/WI 60-02

SPEC ID: 27680

MiTek Canada, Inc.
100 Industrial Road
Bradford, ON L3Z 3G7
Canada

This report is for the exclusive use of Intertek's Client and is provided pursuant to the agreement between Intertek and its Client. Intertek's responsibility and liability are limited to the terms and conditions of the agreement. Intertek assumes no liability to any party, other than to the Client in accordance with the agreement, for any loss, expense or damage occasioned by the use of this report. Only the Client is authorized to permit copying or distribution of this report and then only in its entirety. Any use of the Intertek name or one of its marks for the sale or advertisement of the tested material, product or service must first be approved in writing by Intertek. The observations and test results in this report are relevant only to the sample tested. This report by itself does not imply that the material, product, or service is or has ever been under an Intertek certification program.

PRODUCT: Mitek Canada Inc. Metal Truss Plates with structural graded chords and webs as per NLGA grading rules.

See enclosed Listing MCI/WI 60-02 or design box.

Attribute	Value
Assemblies	Floor / Ceiling Assemblies
Criteria	UL 263 (2003)
Criteria	UBC 7-1 (1994)
Criteria	CAN / ULC S101 (2004)
Criteria	NFPA 251 (2006)
Criteria	CAN / ULC S101 (2007)
Criteria	ASTM E119 (2008a)
Criteria	ASTM E119 (2010)
Criteria	UL 263 (2011)
CSI Code	06 17 00 Shop-Fabricated Structural Wood
Intertek Services	Certification
Listed or Inspected	LISTED
Listing Section	ROOF/CEILING, FLOOR/CEILING, BEAM & COLUMN ASSEMBLIES
Report Number	3108028/3115131
Spec ID	27680

DRAWING INDEX

MCI/WI 60-02

MCI/WI 60-02

Division 06 – Wood, Plastics, and Composites
 06 17 00 Shop-Fabricated Structural Wood
 06 17 33 Wood I-Joists

Page 1 of 2

MiTek Canada Inc.
Design No. MCI/WI 60-02
Metal Truss Plates
Floor/Ceiling Assembly
ASTM-E119, CAN/ULC-S101, NFPA-251, UBC-7-1, UL 263
Rating: 1 Hour – Unrestrained

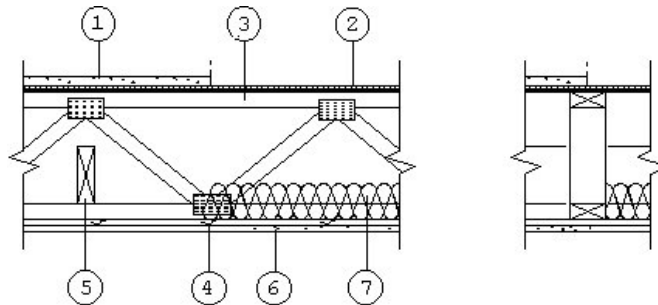

Finish Rating: 22 Minutes
 STC 50 with Insulation & Resilient Channels
 STC 55 with 1-1/2 in. of Lightweight Concrete

1. TOPPING (Optional): Subject to design and project limitations, these systems may be augmented with a lightweight floor topping mix containing perlite or vermiculite aggregate.

2. FLOORING: Min. 5/8 in. (15.9mm) plywood or O-2 grade waferboard or strandboard. See below for spacing >16 in. (400mm) on center (oc).

SUB-FLOORING: Sub-floor panels to conform to one of the following:

Max. Joists Spacing	Plywood & O-2 Grade Waferboard and Strandboard	Waferboard and Strandboard R-1 & O-1 Grade
16 in. (400mm)	5/8 in. (15.9mm)	5/8 in. (15.9mm)
19.2 in. (500mm)	3/4 in. (19.0mm)	3/4 in. (19.0mm)
24 in. (600mm)	3/4 in. (19.0mm)	3/4 in. (19.0mm)

SUB-FLOORING FASTENING: Min. length of fastener for sheathing and subfloor attachment for thickness from 5/8 in. (15.9mm) to 3/4 in. (19.0mm) thick is:

A. Common or Spiral Nail – 2 in. (51mm) (Canada); 8d (0.131 in. dia. x 2.5 in. long) (US).

B. Ring Thread Nail – 1-3/4 in. (45mm) (Canada); 6d (0.120 in. dia. x 2 in. long) (US).

Nail spacing shall be 6 in. (150mm) oc along butt edges of panel and 12 in. (300mm) (Canada) and 10 in. (US) oc along intermediate support.

3. CERTIFIED MANUFACTURER: MiTek Canada Inc.

CERTIFIED PRODUCT: MiTek Metal Truss Plates

Listed fire designs are based on systems designed for structural and functional performance in accordance with MiTek Canada Inc. procedures. All designs are tested in unrestrained configuration. The chord materials are structural rated lumber material as graded under NLGA-1993 Standard Grading rules for Canadian Lumber

Date Revised: April 20, 2016
 Project No. 3115131



Valued Quality. Delivered.

MCI/WI 60-02 (2 of 2)

Division 06 – Wood, Plastics, and Composites
06 17 00 Shop-Fabricated Structural Wood
06 17 33 Wood I-Joists

Page 2 of 2

or graded by an inspection bureau or agency approved by the United States Department of Commerce Board of Review of the American Lumber Standards Committee with chord sizes of 3 x 2, 4 x 2, 5 x 2.

CERTIFIED MODELS: Includes wood web floor truss designs with metal truss plates manufactured by MiTek Canada Inc. having a min. depth of 10 in. and spaced up to max. of 24 in. oc for floor/ceiling systems.

MiTek Canada Inc. Metal Truss Plates with structural graded chords as per NLGA grading rules. All floor trusses are to be designed and sealed by a Professional Engineer.

4. FURRING CHANNELS (Resilient Channels): 7/8 in. deep with 26 GA galvanized steel wired to underside of each truss with double strands of 18 GA steel tie wire or screwed to each truss with 1-1/4 in. Type S drywall screws. Double rows of furring channels at each gypsum wallboard joist (at least 3 in. apart).

5. BRIDGING/STRONGBACK: 2 x 6 SPF #2 to be screwed to the bottom chord with two 3 in. screws and to be spaced at 7 ft. oc.

6. GYPSUM BOARD: 4 ft. x 10 ft. x 5/8 in. Type C (listed Firecode C or Westroc Fireboard C) with edges running perpendicular to the furring channels. Screwed to channels with 1-1/4 in. Type S bugle-head drywall screws set at 12 in. oc and 1-1/2 in. from edges of board (min.). All joints to be taped. Joints and screw heads covered with 2 layers of gyproc joint filler.

7. INSULATION (Optional): Where design requires insulation, it shall be 1-1/2 in. (38mm) thick mineral wool insulation batts. Where insulation is optional, it may be 3-1/2 in. (89mm) thick fiberglass insulation batts with density 0.75 lb/cu.ft. All batts are to be placed between bottom joist flanges and supported by metal furring channels. All butt joints shall be over furring channels.

8. SUSPENDED CEILING SYSTEM (Optional, Not Shown): Any suspended ceiling system may be selected which satisfies the following criteria:

- A. It must be a fire rated system, and be installed within the terms of its listing.
- B. In lieu of a finish rating, any suspended ceiling design may be used that is part of a listed assembly, utilizing a wood deck and wood framing, that has a fire resistance rating equal to or greater than the rating assigned to the MiTek Canada, Inc. assembly.
- C. It must be suspended in accordance with the terms of its listing and a min. of 7-1/2 in. below the joist.
- D. Penetrations such as ducts, air diffusers, and fixtures must be protected in such a manner as to conform to the terms of the listing of the suspended ceiling system.

Date Revised: April 20, 2016
Project No. 3115131



Valued Quality. Delivered.